

SmartClass™ ADSL

ADSL and IPTV Service Installation Tester



Key Features

- All-in-one tool for broadband services installation, including copper, ADSL 1/2/2+, IP data, and IP video testing
- Fast and easy CableCheck copper test for ADSL2+: longitudinal balance, capacitance, DVOM, and loadcoil counter
- Thorough ADSL analysis, including graphical bits-per-tone and SNR-per-tone
- IPTV STB emulation and quality of service (QoS) testing for broadcast and VOD services
- ADSL Through mode enables technician to analyze DSL statistics while viewing the IPTV stream
- Full protocol suite to verify connectivity with ATM OAM F4 and F5, PPP, static and dynamic IP, DNS support, IP PING, TRACERT, HTTP, and FTP
- Ethernet Terminal Equipment (TE) mode to quickly isolate customer premises equipment (CPE); Through mode to replace customer modem



The JDSU SmartClass ADSL is the ideal tool for the technician installing and maintaining asymmetrical digital subscriber line (ADSL) services. The tester enables the technician to test loop quality, verify ADSL signal and performance, and validate the customer's Internet connection with unprecedented ease and speed.

SmartClass ADSL provides a full set of copper tests that qualifies the customer loop for the delivery of newer services such as Internet protocol television (IPTV) including longitudinal balance, a key copper metric to ensure external noise and interference will not impact the quality of the IPTV streams with intermittent pixelization and other disruptive effects. Digital volt-ohm meter (DVOM), distance-to-short, leakage, opens/capacitance, and loadcoil counter tests guarantee the copper loop does not exhibit connection issues and that the quality of the copper pair is within allowed standards for ADSL2+ transmission in terms of loop length and isolation. The unique CableCheck sequence provides a very easy and fast method to qualify the copper loop for ADSL2+ services with a pass/fail indication and programmable thresholds. The full-featured ADSL tests quickly verify provisioned rates and quality, including up/down actual and max rates, margin, attenuation, capacity, TX power, errors, alarms, asynchronous transfer mode (ATM) optical amplifier module (OAM) and stats, Ethernet stats, and bipolar transistor (BPT) graphs.

In addition, the SmartClass ADSL supports the storage and retrieval of pre-set configurations and allows technicians to transfer results to a person computer using a universal serial bus (USB) connection. The instrument's features, including its rugged design and field-replaceable AA batteries, make it the essential ADSL installation tool.

ADSL and IPTV Overview

ADSL2+ has emerged as an IPTV-enabling technology of choice for network operators and services providers seeking new revenue streams and competitive positioning. At the same time consumers are signing up for multiple services in this very competitive environment expecting the best service quality, making it imperative that operators quickly and cost-effectively install ADSL2+ lines with the confidence that their complex triple-play services are working well.

Delivery of ADSL services requires a single copper pair configuration of a standard voice circuit with an ADSL modem at each end of the line, creating three information channels—a high-speed downstream channel, a medium-speed upstream channel, and a plain old telephone service (POTS) channel for voice. Data rates depend on several factors including the length of the copper wire, the wire gauge, presence of bridged taps, and cross-coupled interference. The line performance increases as the line length is reduced, wire gauge increases, bridged taps are eliminated and cross-coupled interference is reduced or is canceled out by a good longitudinal balance characteristic of the copper wire. The modem located at the subscriber's premises is called an ADSL transceiver unit-remote (ATU-R), and the modem at the central office is called an ADSL transceiver unit-central office (ATU-C). The ATU-Cs take the form of circuit cards mounted in the digital subscriber line access multiplexer (DSLAM), while a residential or business subscriber connects their PC and ATU-R modem to a telephone outlet on the wall.

ADSL2 has been specifically designed to improve the rate and reach of ADSL largely by achieving better performance on long lines. ADSL2 accomplishes this by improving modulation efficiency, reducing framing overhead, achieving higher coding gain, improving the initialization state machine, and providing enhanced signal processing algorithms. ADSL2+ further improves on the ADSL2 standard by allocating additional spectrum for downstream data, dramatically improving the data rate over ADSL2 or ADSL.

With its improved downstream rates, ADSL2+ is the preferred technology to deliver IPTV. IPTV requires the installation of a set-top box (STB) to decode the compressed video stream for both broadcast and video-on-demand (VoD) services. But transmitting IPTV streams through the network is far more challenging than other broadband services. Broadband applications other than IPTV (such as web browsing and file sharing) mainly use IP/TCP (Internet protocol/transmission control protocol) with acknowledgment that sent packets have been received and a retransmission, in case of lost packets. Unlike IP data services, IPTV is a highly compressed, real-time application, and lost video packets caused by intermittent problems with the transport or video stream can directly be visible to the user in the form of pixelization, blurring, and frame freezes. In addition, poor transaction quality (to receive program channels) and poor overall content quality may also occur, further impacting the customer experience.

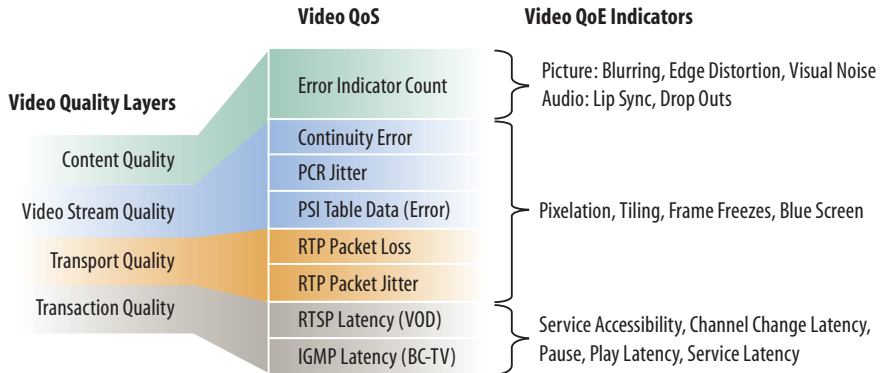

Measuring ADSL and IPTV Performance

CABLE CHECK	
TEST	STATUS
DVOM	OK
CAPACITANCE	IN PROGRESS
BALANCE	PENDING
LOADCOIL	PENDING
X - Cancel	

The SmartClass ADSL can be used to verify service delivery at the provisioned bit rates and quality levels through a quick sync check at various points along the customer circuit (ATU-R, network interface device [NID], splice case, cross box, main distribution frame [MDF], DSLAM). If the tester cannot synchronize with the DSLAM, the SmartClass ADSL provides the copper tests needed to check the wire pair for service affecting faults, or in the worst case helps find a new serviceable pair. In addition to DVOM, the included capacitance (opens), longitudinal balance, and load coil counter tests help identify unique ADSL problems in the convenient CableCheck test sequence. If the delivered service is slower than expected, the SmartClass ADSL provides resistance and opens tests to verify the presence of service-affecting bridged taps or the balance test to assess noise immunity.

Separately, a poorly balanced copper wire will pick up noise that contributes to video packet loss (continuity errors). The copper wire can be checked using the SmartClass ADSL load coil counter to count the number of service-choking load coils on the line, as well as monitor for very high noise levels. The bits-per-tone and SNR-per-tone graphs are handy to correlate dips in performance with specific frequencies and crosstalk.

SmartClass ADSL also enables technicians to verify end-to-end IP connectivity with IP PING and trace route. Other tests include the FTP throughput test, to ensure the network supports the requested bandwidth, and the HTTP Web test, that identifies problems related to dedicated websites.

With the IPTV software option, technicians can quickly verify the availability of IPTV service and its required bandwidth. The QoS parameters, such as continuity error, Program Clock Reference (PCR) jitter, and packet identifier (PID) map help indicate video stream quality problems. Content quality issues are determined by the error indicator count, transport quality metrics can be measured with the IP packet jitter and real-time transport protocol (RTP) packet loss features, and the “zap-time” presented by the Internet group management protocol (IGMP) or real-time streaming protocol (RTSP) latency judges the transaction quality.

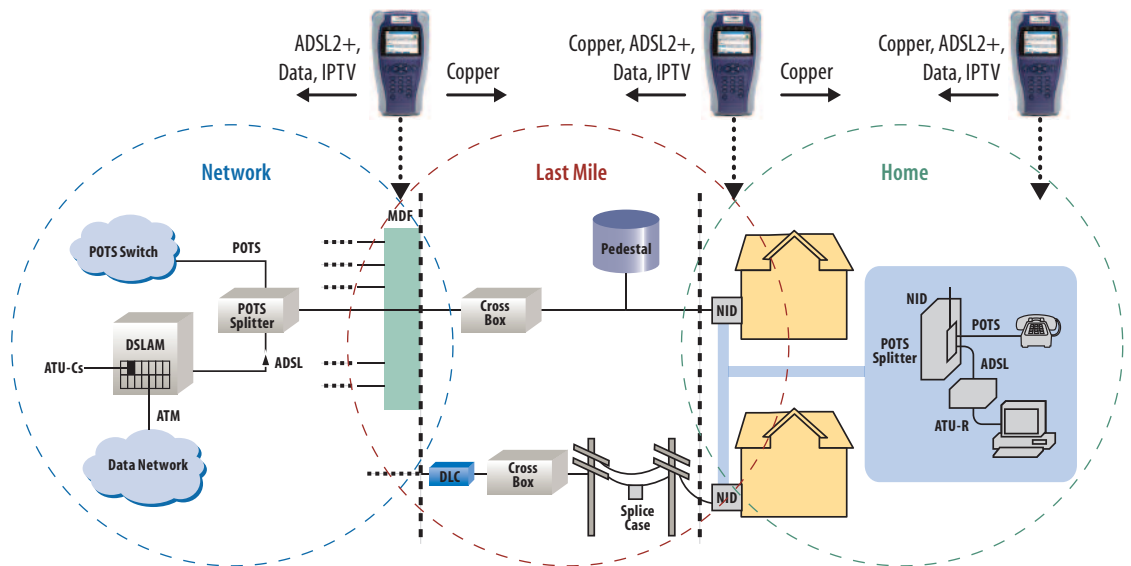

Specifications

Configurations

ADSL Annex A

ADSL Annex B

Cu-ADSL Annex A

Cu-ADSL Annex B

ADSL Specifications

Standard Compliance,

ADSL over POTS Modem

– ANSI T1.413-1998, Issue 2

– ITU-T G.992.1 Annex A (G.DMT)

– ITU-T G.992.2 Annex A (G.lite)

– ITU-T G.992.3 Annex A, L, M

– ITU-T G.992.5 Annex A (ADSL2+)

– ITU-T G.992.5 Annex L (RE-ADSL)

– ITU-T G992.5 Amendment 1

Standard Compliance,

ADSL over ISDN Modem

– ITU-T G.992.1 Annex B (G.DMT)

– ITU-T G.992.3 Annex B (G.DMT.BIS)

– ITU-T G.992.5 Annex B (ADSL2+)

General Settings

– Auto Sync

– Auto or manual framing mode

Physical Layer Feature Support

– Actual and maximum bit rates capacity

– Noise margin

– Attenuation

– Modern state

– TX power

– Far vendor ID, revision

– Graphical display of BPT (bits-per-tone)

– Re-sync counter

– Graphical display of SNR (SNR-per-tone)

– Fast or interleaved

ADSL Errors

– LOS (Loss of Sync)

– LOF (Loss of Frame)

– LOP (Loss of Power)

– CRC (cyclic redundancy check)

– HEC (header error correction)

– FEC (Forward Error Correction)

– Modem errors

PPP/IP Connectivity

– BRAS: PAP/CHAP

– IPCP

– NAT

– PPPoA, PPPoE, IPoA, IPoE, Bridged

– RFCs 2364, 2516, 1483, 2684

Through Modes

– Bridged Ethernet

– IPoE

– IPoA

– PPPoE

– PPPoA

ATM

VCC scan: up to five VPI/VCI

OAM F4/F5 near and far loopbacks

IP

– MAC address

– WAN/LAN status screens

– GATEWAY/DNS screen

– DHCP client on WAN and LAN

– IP release/renew

– DNS support WAN and LAN

– DHCP server on LAN

IP PING

– IP PING: TX/RX, received, delay

– PING count, PING size

– PING to URL (DNS)

– Remote PING monitor

TRACERT

– IP, name, hops, delay

Web Test (HTTP)

– URL

– Download status

– File size

– Time

– Rate

FTP

– URL/file

– Connection status

– Time

– File size Kb

– Rate kBps

DNS

Configure up to three manual addresses

Ethernet Statistics

– RX/TX bytes

– RX/TX frames

– RX/TX errors

– Collisions

ATM Statistics

– ATM OAM F4/5 near and far loopback count

– UP/DN good and idle cell count

– Bad HEC cell count

– Dropped cell count

– TX/RX PDUs

– TX/RX AAL bytes

– TX/RX total error count

Copper Test Specifications

Test	Range	Resolution	Accuracy
AC Volts	0 – 300 Peak	1 V	2% ± 1 V
DC Volts	0 – 300 (VDC + Peak AC)	1 V	2% ± 1 V

Resistance

Resistance	Resolution	Accuracy
0 – 999 Ω	1	2% ± 2.5 Ω
1 – 9.99 kΩ	10	2% ± 2.5 Ω
10 – 99.9 kΩ	100	2% ± 2.5 Ω
100 – 999 kΩ	1 k	2% ± 2.5 Ω
1 – 9.9 MΩ	10 k	6.5% ± 2.5 Ω
10 – 100 MΩ	100 k	6.5% ± 2.5 Ω

Leakage

Leakage	Resolution	Accuracy
0 – 999 Ω	1	2% ± 2.5 Ω
1 – 9.99 kΩ	10	2% ± 2.5 Ω
10 – 99.9 kΩ	100	2% ± 2.5 Ω
100 – 999 kΩ	1k	2% ± 2.5 Ω
1 – 9.9 MΩ	10k	6.5% ± 2.5 Ω
10 – 100 MΩ	100k	6.5% ± 2.5 Ω

Distance to Short

0 – 30k ft/10 km	1 ft/1 m
------------------	----------

Capacitance/Opens

0 – 2,999 ft/999 m	1 ft/0.1 m	2.5% ± 45 pF
0 – 44.9 nF		
3k ft/1 km – 66k ft/20 Km	1 ft/0.1 m	2.5% ± 45 pF
45 nF – 1.04 μ		

DC Current

1 – 110 mA	1 mA	± 2% ± 1 mA
------------	------	-------------

Longitudinal Balance

35 – 85 dB	1 dB	2 dB
------------	------	------

Load Coil Counter

0 – 27k ft/8230 m	up to 5	± 1
-------------------	---------	-----

IP Video

Modes

- Terminate over ADSL2+ WAN interface

Set Top Box Emulation

- IGMPv2 emulation client
- Single IP video stream
- IGMP message status/decode status/error message
- RTSP emulation client

Service Selection Transport Stream

- MPEG2-TS Broadcast: UDP/RTP
- MPEG2-TS Video on Demand (VOD): UDP/TCP
- ISMA Broadcast
- ISMA VoD: UDP/TCP

- UT Starcom Rolling Stream

Video Source Address Selection

- URL and Port Number

QoS

- TS PCR Jitter
- IGMP Latency (Zap Time)
- RSTP Latency (Zap Time)
- TS Continuity Error Event Count
- TS Error Indicator Set Count
- TS Synchronization Errors Count

Video Stream Data Rates

- Connection Status
- Total
- Video
- Audio
- Data

IP Packet Analysis

- Total IP packets RX count
- Max packet jitter
- IP packet jitter
- RTP packets lost, count
- RTP OOS, count
- RTP errors, count

PID Analysis

- PID number
- PID type (video, audio, data)
- PID description

Signaling Protocol Message Decode

- IGMP messages
- RTSP messages

Test Access

- ADSL1, 2-wire I/F
- ADSL 2, 2-wire I/F
- ADSL 2+, 2-wire I/FIP packet analysis

Standards

- RFS-2236, IGMP
- RFC-2326, RTSP
- ISO (IEC 13818), video transport stream and analysis
- ETSI TR 10-290 V2.1, video measurements
- TFC-1483; 2684, ATM AAL5
- RFC-2364, PPPoAALS

General specifications

Languages

- English, Chinese, German, Italian, Spanish, Portuguese

Power supply

- 4 AA field-replaceable batteries (NiMH and or Alkaline)
- Operating time: about 20 on/off cycles and tests on a full charge, depending on usage and conditions
- Auto power down (adjustable)
- Charging time 3 to 4 hours for fast charge, overnight for maximum charge and performance
- AC line operation via external adapter/charger

Permissible ambient temperature

- Nominal range of use -5°C (23°F) to $+50^{\circ}\text{C}$ (122°F)
- Storage and transport -30°C (-22°F) to $+60^{\circ}\text{C}$ (140°F)

Humidity

- Operating humidity 10% to 80%

Physical specifications

- Size (H x W x D) 230 x 120 x 50 mm (9.05 x 4.72 x 1.97 in)
- Weight, including batteries < 1.1 kg (2.5 lbs)
- Weight without accessories 0.6 kg/1.5 lbs
- Display 240 x 160 monochrome display

CE Marked

Ordering Information

Order number	Description
CSC-DSLISL-P2	ADSL Silver package complete (Annex A)
CSC-DSLISL-P2B	ADSL Silver package complete (Annex B)
CSC-DSLGLD-P3	Copper and ADSL Gold Package complete (Annex A)
CSC-DSLGLD-P3B	Copper and ADSL Gold Package complete (Annex B)
SCASWVIDEO	SmartClass ADSL IP Video Software Option

Packages include standard accessories, USB cable, and test leads.

All statements, technical information and recommendations related to the products herein are based upon information believed to be reliable or accurate. However, the accuracy or completeness thereof is not guaranteed, and no responsibility is assumed for any inaccuracies. The user assumes all risks and liability whatsoever in connection with the use of a product or its application. JDSU reserves the right to change at any time without notice the design, specifications, function, fit or form of its products described herein, including withdrawal at any time of a product offered for sale herein. JDSU makes no representations that the products herein are free from any intellectual property claims of others. Please contact JDSU for more information. JDSU and the JDSU logo are trademarks of JDS Uniphase Corporation. Other trademarks are the property of their respective holders. ©2008 JDS Uniphase Corporation. All rights reserved. 30137426 006 0308 SCNONCU.DS.ACC.TM.AE

Test & Measurement Regional Sales

NORTH AMERICA TEL: 1 866 228 3762 FAX: +1 301 353 9216	LATIN AMERICA TEL: +55 11 5503 3800 FAX: +55 11 5505 1598	ASIA PACIFIC TEL: +852 2892 0990 FAX: +852 2892 0770	EMEA TEL: +49 7121 86 2222 FAX: +49 7121 86 1222	www.jdsu.com/test
---	--	---	---	---